

E32 Sliding System

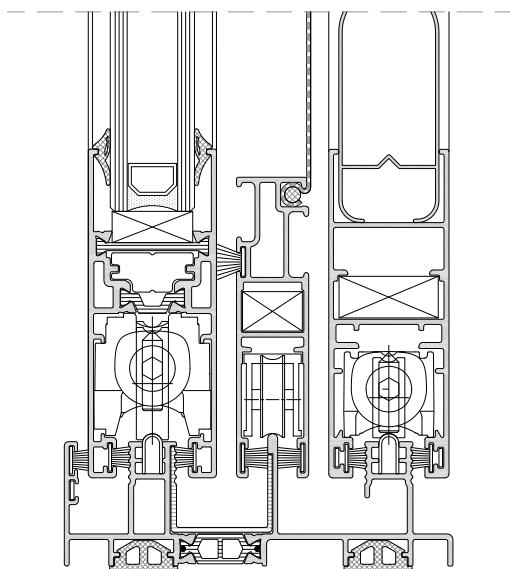

Featuring smart design, simpler parts and the lightest aluminium construction in its class, the sliding system E32 allows easiest and quickest fabrication and installation, compared to other similar products. For the casings installer, this translates into less installation time and trouble free workflow.



Performance

Air Permeability:	up to Class 4
Watertightness:	up to Class 7A
Resistance to wind load:	up to Class C3
Thermal transmittance (U_f):	from 2.9 W/(m²K)
Operating forces:	Class 1

Typologies

- Single, double, triple & quadruple sliding with or without fly screen and shutter
- Sliding inside a wall pocket

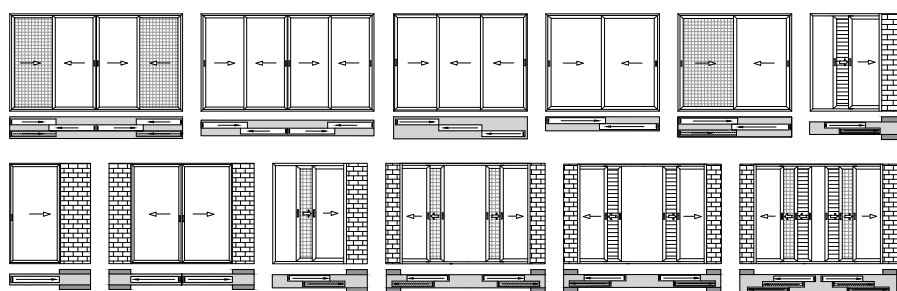

Technical features

Single & double-glazing option
Glazing infill range: 10 ÷ 22 mm
Max. sash width: 1600 mm (height up to 1500 mm)
Max. sash height: 2300 mm (width up to 1300 mm)
Single rail width: 42 mm
Double rail width (2x sash): 85.5 mm

Hardware

Slide mechanism
Max. sash weight: 90 kg
Double rollers
Single, Multiple point or Inline locking mechanism.

Surface treatment options

RAL colours
ETEM colours
Anodising
Wood effects
Quality Standards:
- QUALICOAT
- QUALANOD
- QUALIDECO

Production certificates

- EN ISO 9001
- EN ISO 14001
- OHSAS 18001